

METOS[®]
BY PESSL INSTRUMENTS



DUALEX[®] - Optical Leafclip Meter

*Measuring the chlorophyll and
polyphenols contents in plants.*



www.metos.at

Sensor



DUALEX® is a **leafclip meter** that can accurately determine the **chlorophyll, flavanols and anthocyanins contents** in leaves.

DUALEX® also provides the NBI® (Nitrogen Balanced Index), a **good indicator of plant nitrogen status**.

DUALEX® is mainly used in Plant Sciences for **abiotic stress studies** (physiology, agronomy, ecology, ...).

Zoom on the Product

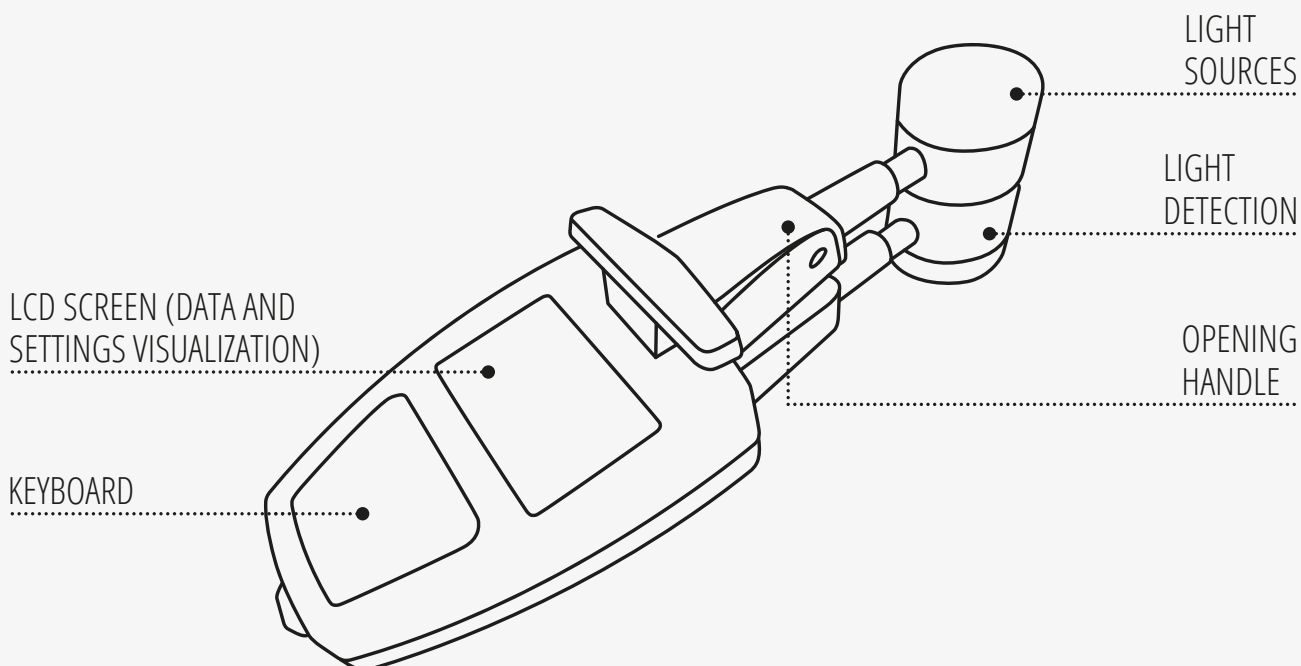

Features

✓ **Non-destructive measurement**

Clipping the leaf **doesn't cause any damage**.

With DUALEX® it's possible to measure the same leaf multiple times.

✓ **Adapted to experimentation**

DUALEX® offers the **possibilities to:**

- Remove the last measurement.
- Manage measurement groups (two levels of classification).
- Record more than 10,000 multiparametric data.

✓ **Lightweight and compact**

DUALEX® is **easily portable and can be used frequently**. Not sensitive to ambient light, DUALEX® **can be used in labs, greenhouses or fields**.

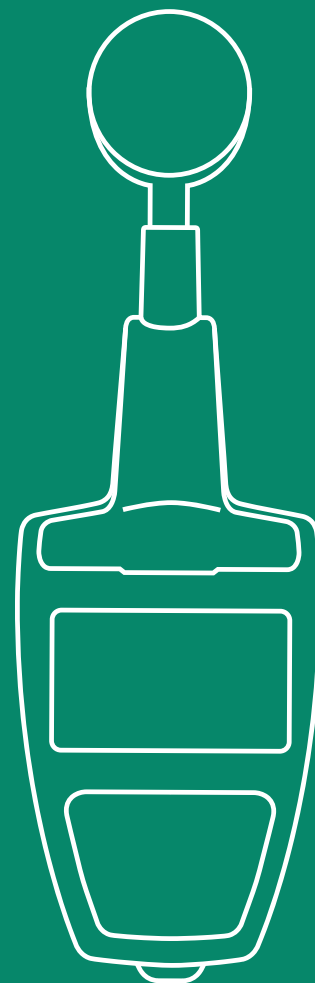

Fast & Simple

With only one clip, in automatic mode, the measurement is recorded each time the device detects the presence of a leaf (manual triggering also available). One measurement takes **less than 1 second**.

Reliable & Practical

With a measurement area of 19,6 mm², DUALEX® has a good sampling area. Thanks to a 8 cm long clip it's **possible to measure the middle of the leaf** where chlorophyll is less variable and more representative.

Principles

Accurate measurement of chlorophyll

DUALEX® measures the chlorophyll content of leaf thanks to a transmittance ratio at two different wavelengths. One in the far-red **5** absorbed by chlorophyll and one in the near-infrared **6** as reference.

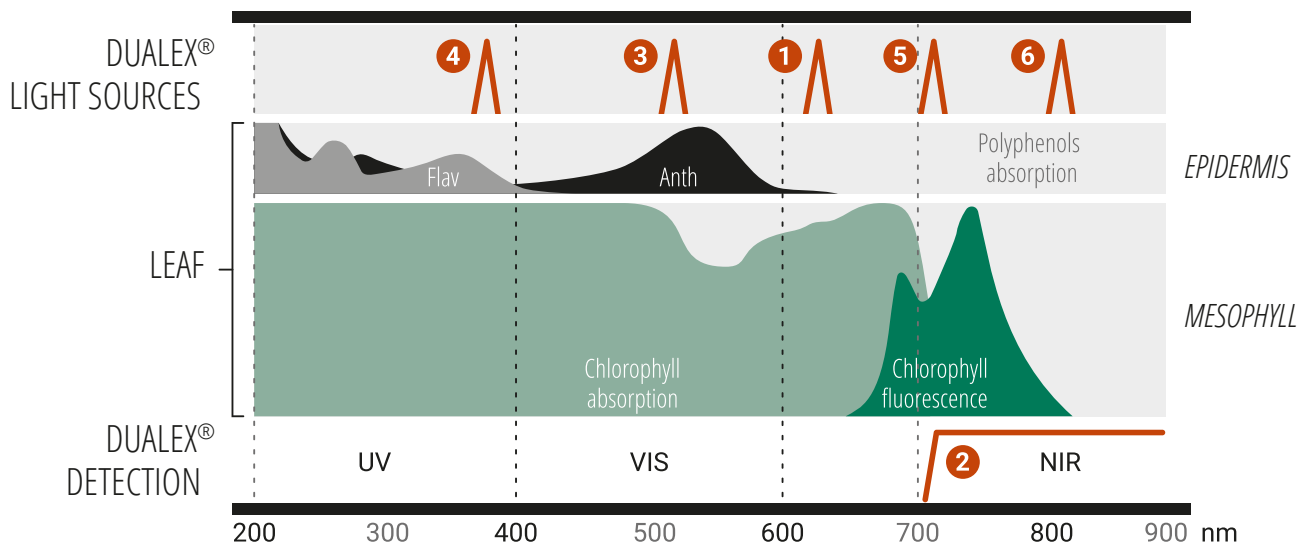

The only leafclip sensor to measure flavonols and anthocyanins contents

DUALEX® measures flavonols and anthocyanins content of the leaves epidermis thanks to a differential ratio of chlorophyll fluorescence.

Near-infrared chlorophyll fluorescence is measured under a first reference excitation light not absorbed by polyphenols **1**. It is compared to a second sampling specific light absorbed by polyphenols (e.g. green **3** or anthocyanins or UV **4** for flavonols).

Only a fraction of this light reaches the chlorophyll in the mesophyll and can generate near-infrared chlorophyll fluorescence **2**. This principle of measurement is called the screening effect of polyphenols on chlorophyll fluorescence.

Technical Specifications

Measuring material	Plant leaves
Measuring system	Transmittance and screening effect on chlorophyll fluorescence
Index measured	Chlorophyll (CHL), Flavonols (FLAV), anthocyanins (ANTH), NBI
Accuracy	5%
Reproducibility	4,5% for CHL, 3,5% for FLAV and ANTH
Repeatability	1,3% for CHL, 2% for FLAV and ANTH
Area measured	19,6 mm ²
Leaf thickness	1.5 mm maximum
Measurement time	< 1 s
User interface	LCD screen, Sound warning
Positioning	Internal GPS
Relative accuracy	< 2,5 m (CEP, 50%, 24 h static)
Storage capacity	10 000 multiparametric data
Data output	.csv file
Data transfer	USB
Operating temperature	From 5 to 45 °C
Battery	Li-ion rechargeable
Autonomy	6 hours
Total weight	220 g
Size	205 x 65 x55 mm

DUALEX® case contains:

- Dualex leafclip sensor.
- USB cable and charger.
- Hand wrist strap.
- Cleaning swab.

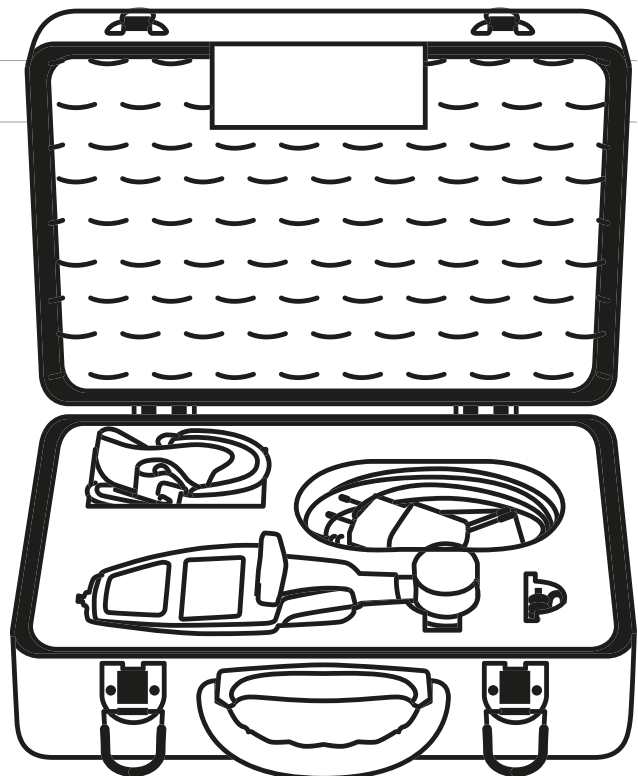

Contact

Pessl Instruments GmbH

Werksweg 107

8160 Weiz, Austria

orders@metos.at

Distributors:

www.metos.at/distributors

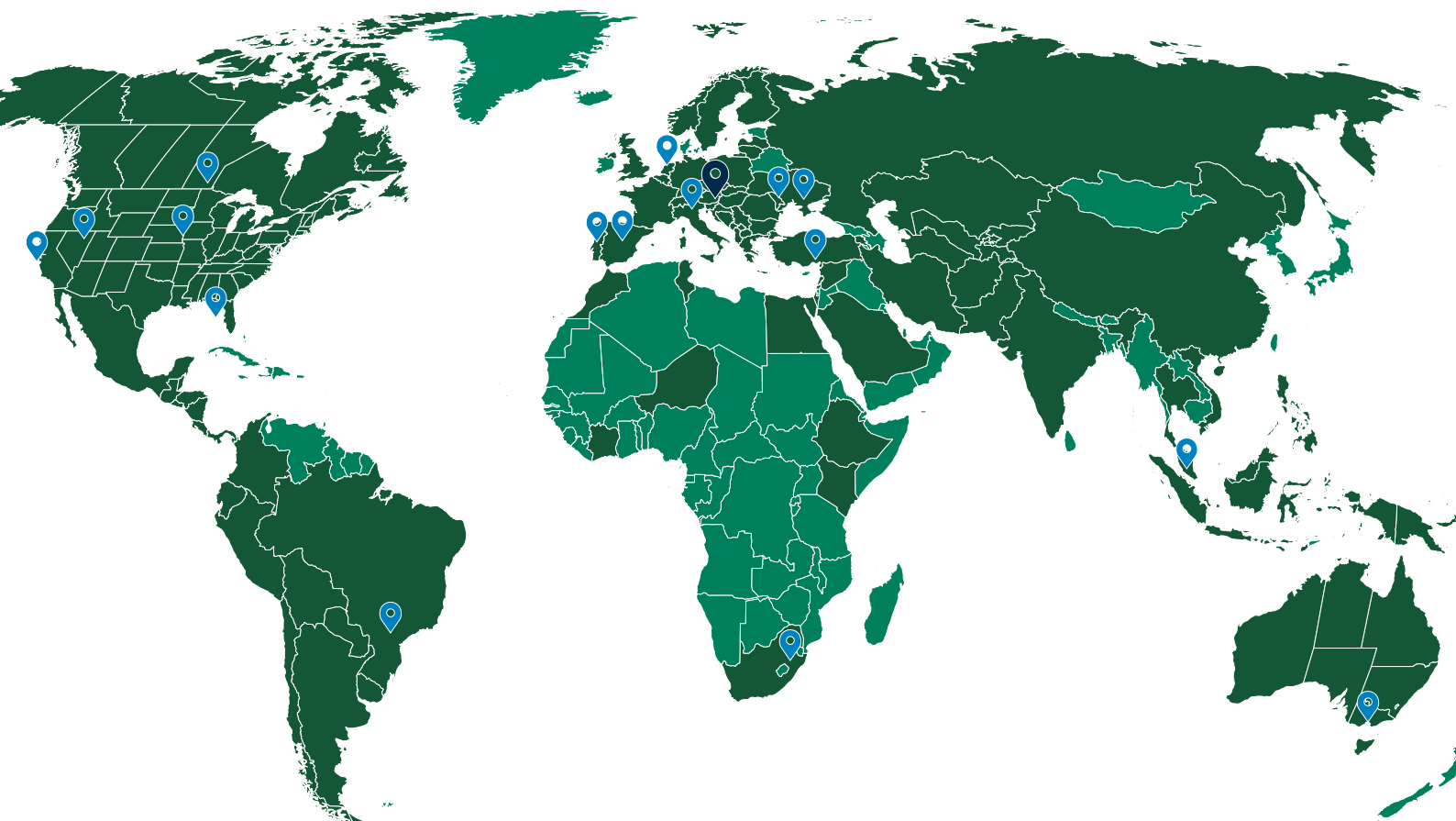

[/pesslinstruments](https://www.facebook.com/pesslinstruments)



[/pesslinstruments_pi](https://www.instagram.com/pesslinstruments_pi)



[/metos_austria](https://twitter.com/metos_austria)



[/company/pesslinstruments](https://www.linkedin.com/company/pesslinstruments)